

STARTING WITH  
SERIAL #071210076

# HSS-10

## PARTS LIST MANUAL



SHOWN WITH OPTIONAL PROCART

### 10" HARDSCAPE SAWS

SKU NO.	MODEL	POWER OPTION
28300	HSS10-4.5S	SUBARU ROBIN ENGINE EX13D W/ CYCLONE AIR CLEANER
28400	HSS10-4H	HONDA ENGINE GX120U1-QXC9 W/ CYCLONE AIR CLEANER
28800	HSS10-1.5B	BALDOR MOTOR 1.5 HP-1PH-60HZ-115/230V-14/7FLA

READ AND UNDERSTAND THE OPERATORS INSTRUCTION MANUAL THOROUGHLY BEFORE ATTEMPTING TO OPERATE THIS EQUIPMENT. Death or serious injury could occur if this machine is used improperly.



## SAFETY MESSAGES



The safety instructions are preceded by a graphic alert message of DANGER, WARNING, or CAUTION.



Indicates an imminent hazard which, if not avoided, will result in death or serious injury.



Indicates an imminent hazard which, if not avoided, can result in death or serious injury.



Indicates hazards which, if not avoided, could result in serious injury and or damage to the equipment.

## GASOLINE Powered Equipment



- Do not operate gasoline powered equipment without adequate ventilation. Carbon monoxide is an invisible, odorless gas that can kill.

## ELECTRICAL Powered Equipment



- ELECTRICAL HAZARD** - Be sure equipment is properly grounded. Failure to comply could kill or result in serious injury.



The engine exhaust from this product contains chemicals known to the State of California to cause cancer, birth defects or other reproductive harm.

## GENERAL INSTRUCTIONS



- You must read and understand the operators instruction manual and all other manuals associated with this machine. For your safety and the safety of others around you, it is extremely important to fully understand how to operate this machine in the way it was intended. Different model machines or older/newer versions of the same model may have different parts and controls that you need to understand. If instructions are not readable or available DO NOT USE this machine and contact the factory for a replacement Manual.
- You must be able to physically handle the bulk weight and power of this machine. If not properly controlled this machine can cause death or serious injury.
- Do not operate this machine in an impaired mental state. You must be able to exercise good judgement and reactions to maintain a safe working environment.
- This is a "one person" machine which means only one operator can be operating the machine at any one time. For the safety of others, maintain a safe operating distance to other personnel. Your work area should be defined and appropriately marked so bystanders and coworkers do not stand or walk near this machine and end up seriously injured by flying debris or exposing them to harmful noise or dust.
- This equipment is for Commercial use. Although this is a "one person" machine your work team should understand how to shut this machine off and quickly get medical help if an accident strikes the operator.
- Keep all guards in place during operation. The guards are to provide protection from inadvertent contact with dangerous moving parts, pinch points, or hot surfaces.
- Wear appropriate Personal Protective Equipment (PPE) including safety glasses, safety boots, work gloves, respiratory protection, hearing protection, and head protection. Do not wear loose clothing that can get tangled in moving parts. Failure to do so could result

in dismemberment or death. **Wear an approved respirator when removing hazardous materials or when grinding/cutting dry materials. Some dust particles such as concrete dust can contain silicate particles which can cause silicosis (a very serious lung disease). Contact NIOSH or OSHA for further details. When wet grinding/cutting, avoid contact with the concrete/asphalt slurry which can cause serious skin irritations.**

- You must maintain this machine per the maintenance schedule in the operator manual. Remember before adjusting, servicing, or fueling this machine, disconnect the source of power to the machine by disconnecting the spark plug (Gas models), or by unplugging the electrical power cord (electric models) or air hose (Pneumatic models) AT THE MACHINE so you can assure yourself it remains unplugged while you are working on it. Do not modify this machine. Use only genuine EDCO parts and accessories. Repairs and service should be performed by approved EDCO dealers or authorized technicians.
- You should look carefully around the area before you begin work so you can identify potential hazards such as deck inserts, pipes, columns, openings, electrical cords or outlets, or any other objects protruding from the slab surface.
- This machine has no brain so you must use your own. There is no substitute for safety. The safety decals on the machine are to serve as a reminder for information you must already know before you begin using this machine. Take a moment to reread the safety decals each time you use the machine. If your machine is missing any decals, contact the factory for a replacement (EDCO 1-800-638-3326).

# PARTS LIST MANUAL

## MODEL HSS10 10" HARDSCAPE SAW

<u>Section</u>	<u>Page Number</u>
Safety Messages and General Instructions . . . . .	2
How To Order Replacement Parts . . . . .	3
Illustration 1: Main Grouping . . . . .	4,5
Illustration 2: Rolling Table Assembly . . . . .	6
Illustration 3: Arbor Assembly . . . . .	7
Illustration 4: Engine Grouping . . . . .	8
Illustration 5: Motor Grouping . . . . .	9
Illustration 6: Optional ProCart . . . . .	10
Illustration 7: Optional Folding Stand . . . . .	11
Illustration 8: Optional Water Pump Kit . . . . .	12,13
Illustration 9: Water Pump Assembly . . . . .	14
Illustration 10: Optional Drain Assembly . . . . .	15
Illustration 11: Optional 115V Water Pump Assembly . . . . .	16
Wiring Diagram for Baldor Motor . . . . .	17
Notes . . . . .	18
Limited Equipment Warranty of Sale . . . . .	Back Page

HOW TO ORDER REPLACEMENT PARTS	FILL IN INFORMATION BELOW
<ul style="list-style-type: none"> <li>❑ To insure product safety and reliability, always use genuine CONTRx Systems replacement parts when making repairs to the equipment.</li> <li>❑ When calling for parts, specify the MODEL and SERIAL number of the machine, which can be found on the NAME PLATE. Keep that information in the space provided. In addition to this information, give part number, description, and quantity as listed on the parts list to your parts representative.</li> <li>❑ Please note: Due to improvements and changes in the equipment, the illustrations shown may be different than the actual machine.</li> </ul>	<p>Date of Purchase _____</p> <p>Model # _____</p> <p>Serial # _____</p> <p>SKU # _____</p>



100 Thomas Johnson Drive, Frederick, MD 21702-4600 USA  
 Phone (301) 663-1600 • 1-800-638-3326  
 Fax (301) 663-1607 • 1-800-447-3326  
 Website: www.edcoinc.com  
 Email: sales@edcoinc.com

# ILLUSTRATION 1 : MAIN GROUPING

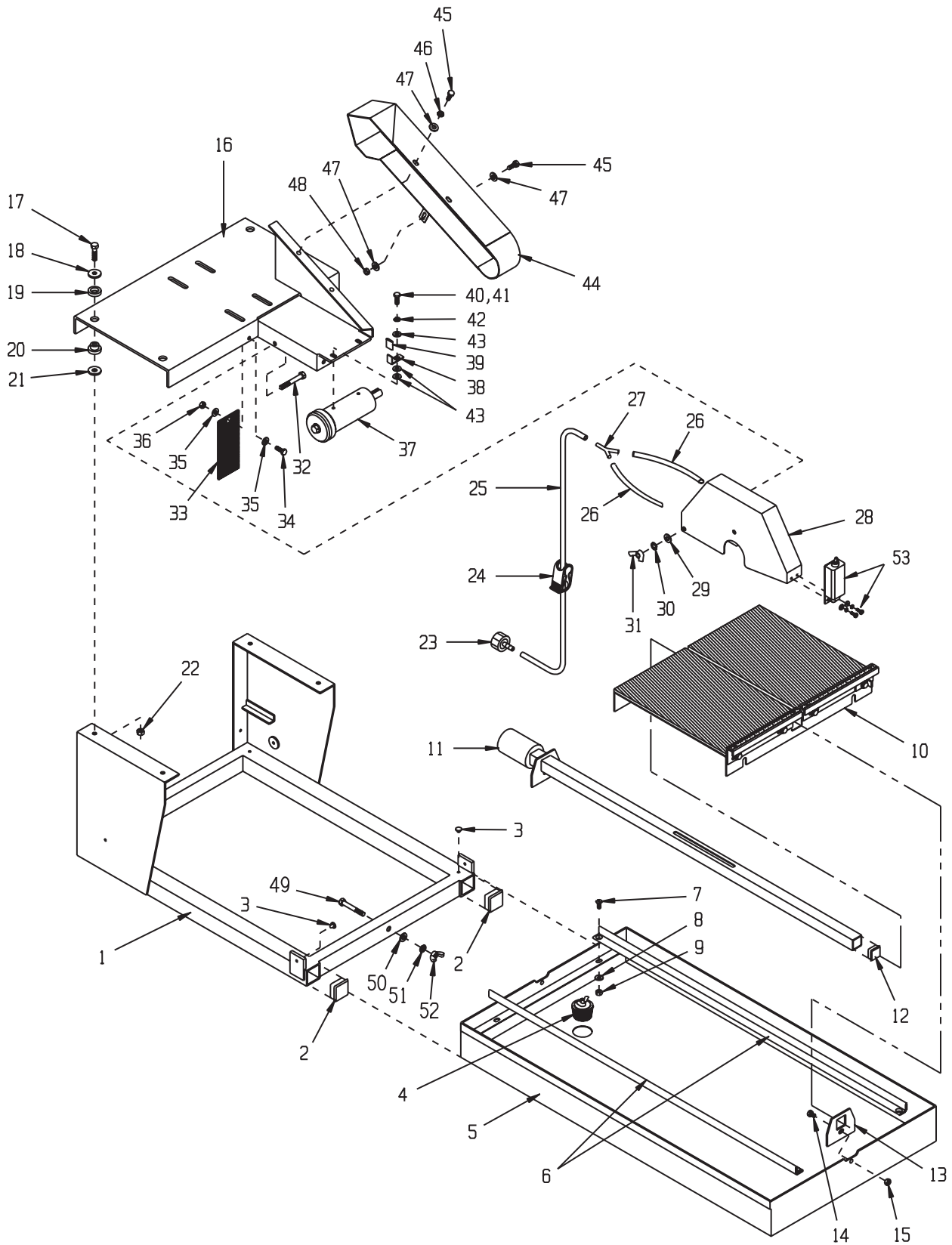

### PARTS LISTING - ILLUSTRATION 1: MAIN GROUPING

ITEM #	PART #	DESCRIPTION	QTY.	ITEM #	PART #	DESCRIPTION	QTY.
1	42201	MAIN FRAME	1	27	99323	BARBED FITTING, "Y" 1/4"HOSE	1
2	42148	PLUG, SQ. TUBE 1-1/2 X 11 GA., BLK	2	28	42113	GUARD, BLADE 10"	1
3	42127	RIVET, NYLON PUSH-IN PANEL	4	29	10213	WASHER, FLAT 5/16 SAE	1
4	40378	STOPPER ASSEMBLY 1-1/2"	1	30	10801	WASHER, LOCK 5/16	1
5	42204	PAN	1	31	10902	NUT, WING 5/16-18	1
6	42102B	TRACK RAIL 33-3/4"L	2	32	10010	SCREW, CAP 5/16-18 X 2-1/2	1
7	11540	SCREW, FLAT HD SLT 1/4-20 X 5/8	4	33	42314	FLAP, SPLASH 2-1/2 X 5-1/4	1
8	10602	WASHER, FLAT 1/4 SAE	4	34	10018	SCREW, CAP 1/4-20 X 3/4	1
9	10861	NUT, KEPS 1/4-20	4	35	10602	WASHER, FLAT 1/4 SAE	2
10	42220	TABLE COMPLETE, ROLLING (REFER TO ILLUS. 2 FOR BREAKDOWN)	1	36	10150	NUT, HEX NYLON LOCK 1/4-20	1
11	42228	VACUUM PORT TUBE	1	37	42114G	ARBOR ASSY. COMPLETE (REFER TO ILLUS. 3 FOR BREAKDOWN)	1
12	51078	PLUG, SQ. TUBE 1 X 14 GA., BLACK	1	38	42128	BRACKET, BLADE GUARD RETAINER	1
13	42229	MOUNTING BRKT., VACUUM PORT TUBE	1	39	42144	COVER, VIBRATION	1
14	10834	SCREW, CAP 1/4-20 X 1/2	2	40	10018	SCREW, CAP 1/4-20 X 3/4	1
15	10861	NUT, KEPS 1/4-20	2	41	10834	SCREW, CAP 1/4-20 X 1/2	3
16	42218	DECK, ENGINE & ARBOR	1	42	10038	WASHER, LOCK 1/4	4
17	10342	SCREW, CAP 5/16-18 X 1-1/2	4	43	10602	WASHER, FLAT 1/4 SAE	4
18	42203	WASHER 5/16"ID X 1"OD X 1/8"THK	4	44	42217	COVER, BELT	1
19	79035	BUSHING, RUBBER 1-1/16"OD X 5/8"ID	4	45	10018	SCREW, CAP 1/4-20 X 3/4	3
20	10225	BUSHING, RUBBER, ENGINE MOUNT	4	46	10038	WASHER, LOCK 1/4	2
21	42224	BUSHING, RUBBER 1"OD X 3/8"ID X 1/8 (USED AS A SHIM WHEN REQ'D.)		47	10602	WASHER, FLAT 1/4 SAE	4
22	10807	NUT, LOCK 5/16-18	4	48	10861	NUT, KEPS 1/4-20	1
*23	11570	INSERT, SWVL.FEM. 1/4HOSE X 3/4GHT	1	49	10341	SCREW, CAP 5/16-18 X 2-1/4	1
24	42131	CLAMP, TUBE, FLOW CONTROL 3/4"	1	50	10213	WASHER, FLAT 5/16 SAE	1
*25	42208	HOSE 1/4"ID X 30"L	1	51	10801	WASHER, LOCK 5/16	1
26	42141	HOSE 1/4"ID X 8"L	2	52	10902	NUT, WING 5/16-18	1
				53	36817	LASER CUTTING GUIDE LIGHT	1

\* NOTE: USED ON UNITS WITH OUT THE WATER PUMP OPTION.  
FOR UNITS WITH THE WATER PUMP - SEE ILLUSTRATION 10.

**ILLUSTRATION 2: ROLLING TABLE ASSEMBLY**

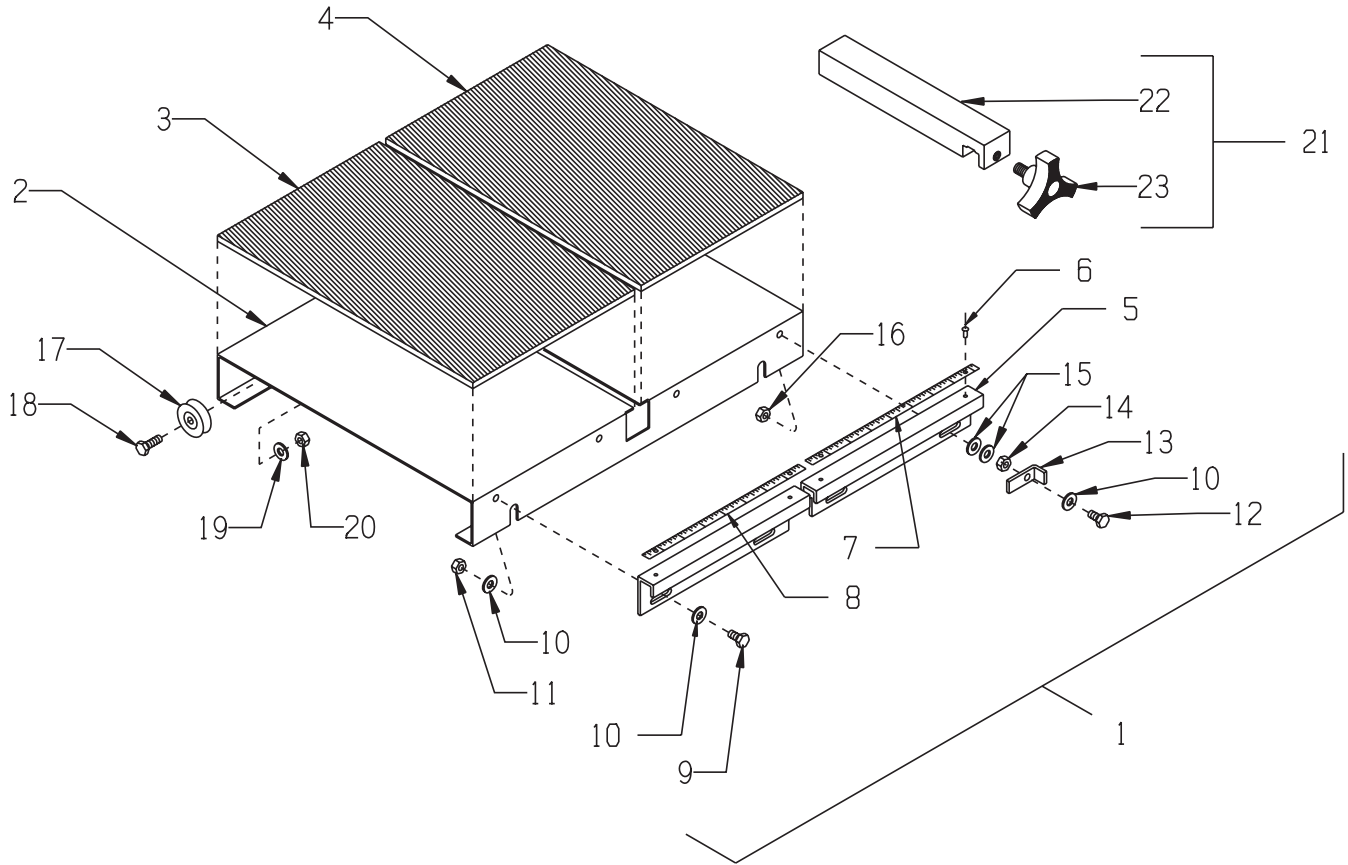

ITEM #	PART #	DESCRIPTION	QTY.	ITEM #	PART #	DESCRIPTION	QTY.
1	42220	TABLE COMPLETE, ROLLING (INCLUDES ITEMS 2 THRU 23)	1	13	42106	LATCH, ROLLING TABLE	1
2	42226	TABLE, ROLLING	1	14	10013	NUT 1/4-20	1
3	42222	RUBBER PAD 12 X 7-1/2 X 3/16	1	15	11704	WASHER, FLAT .257 X .624 X .060THK	2
4	42221	RUBBER PAD 12 X 8 X 3/16	1	16	10015	NUT, LOCK 1/4-20	1
5	42227	TABLE FRONT PANEL (2 PIECES)	1	17	14082	PULLEY BEARING 1-1/4DIA. X 1/4BORE	4
6	11571	RIVET, BLIND 1/8 X .640"L X .250"HD	4	18	10031	SCREW, CAP 1/4-20 X 1	4
7	42136	RULE, ADHESIVE-BACKED, 1-8, L-R	1	19	10602	WASHER, FLAT 1/4 SAE	4
8	42137	RULE, ADHESIVE-BACKED, 1-7, R-L	1	20	10861	NUT, KEPS 1/4-20	4
9	10018	SCREW, CAP 1/4-20 X 3/4	3	21	42205	GUIDE ASSY., STRAIGHT CUT (INCLUDES ITEMS 22 AND 23)	1
10	10602	WASHER, FLAT 1/4 SAE	7	22	42206	GUIDE ONLY, STRAIGHT CUT	1
11	10861	NUT, KEPS 1/4-20	3	23	40425	KNOB, 3-PRONG W/ 3/8-16 X 5/8 STUD	1
12	10031	SCREW, CAP 1/4-20 X 1	1				

### ILLUSTRATION 3: ARBOR ASSEMBLY

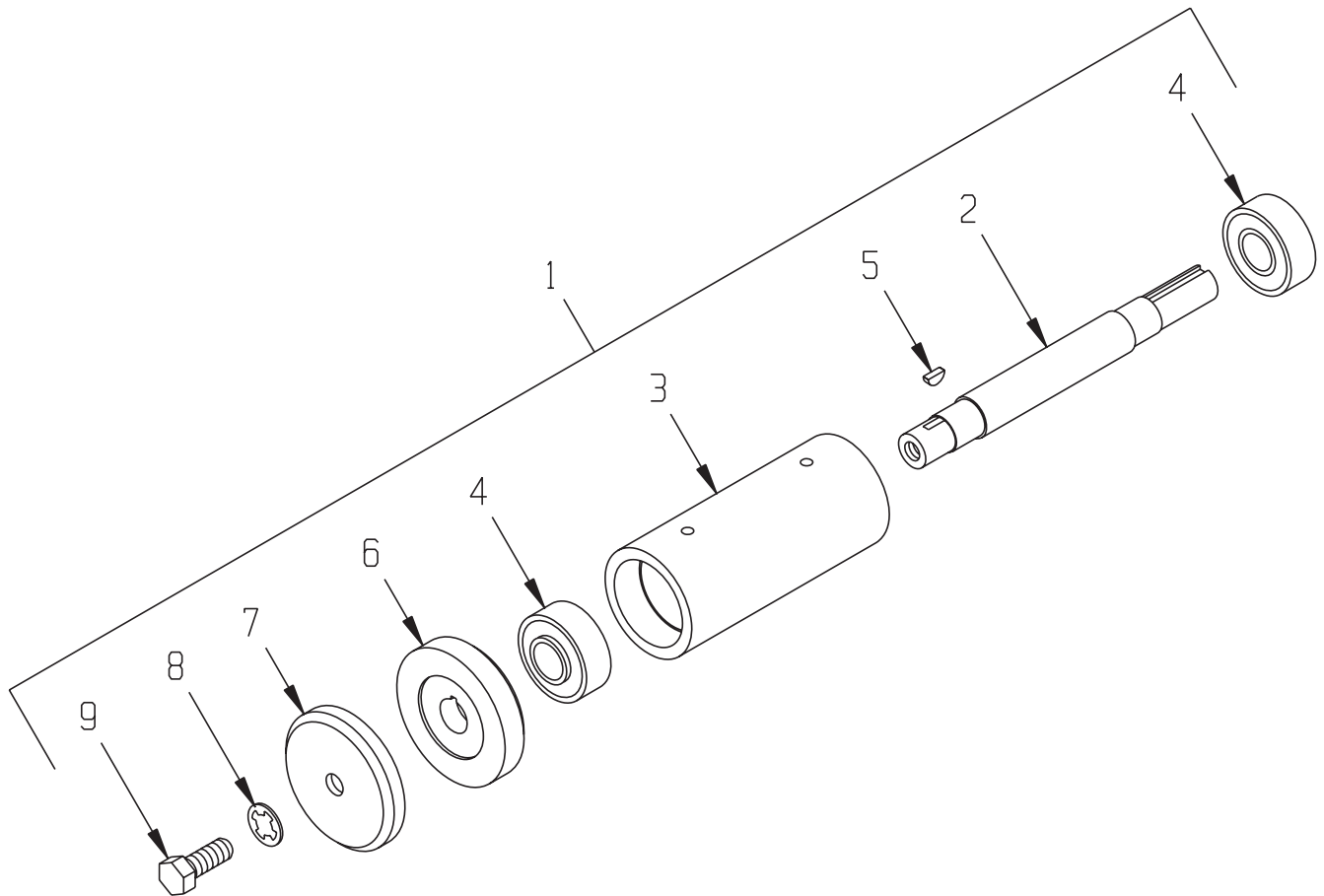

ITEM #	PART #	DESCRIPTION	QTY.
1	42114G	ARBOR ASSY. COMPLETE (INCLUDES ITEMS 2 - 9)	1
2	42115	ARBOR SHAFT 6-3/4"L	1
3	42116	ARBOR HOUSING	1
4	42119	BEARING, RADIAL BALL 17mm X 40mm X .563in	2
5	40036	KEY, WOODRUFF 1/8 X 3/8 (#403)	1
6	42117	ARBOR BACKING PLATE 2-1/2"	1
7	42118	ARBOR BLADE CAP 2-1/2"	1
8	10453	WASHER, LOCK, INT. TOOTH 3/8"	1
9	10021	SCREW, CAP 3/8-24 X 1	1

**ILLUSTRATION 4: ENGINE GROUPING**

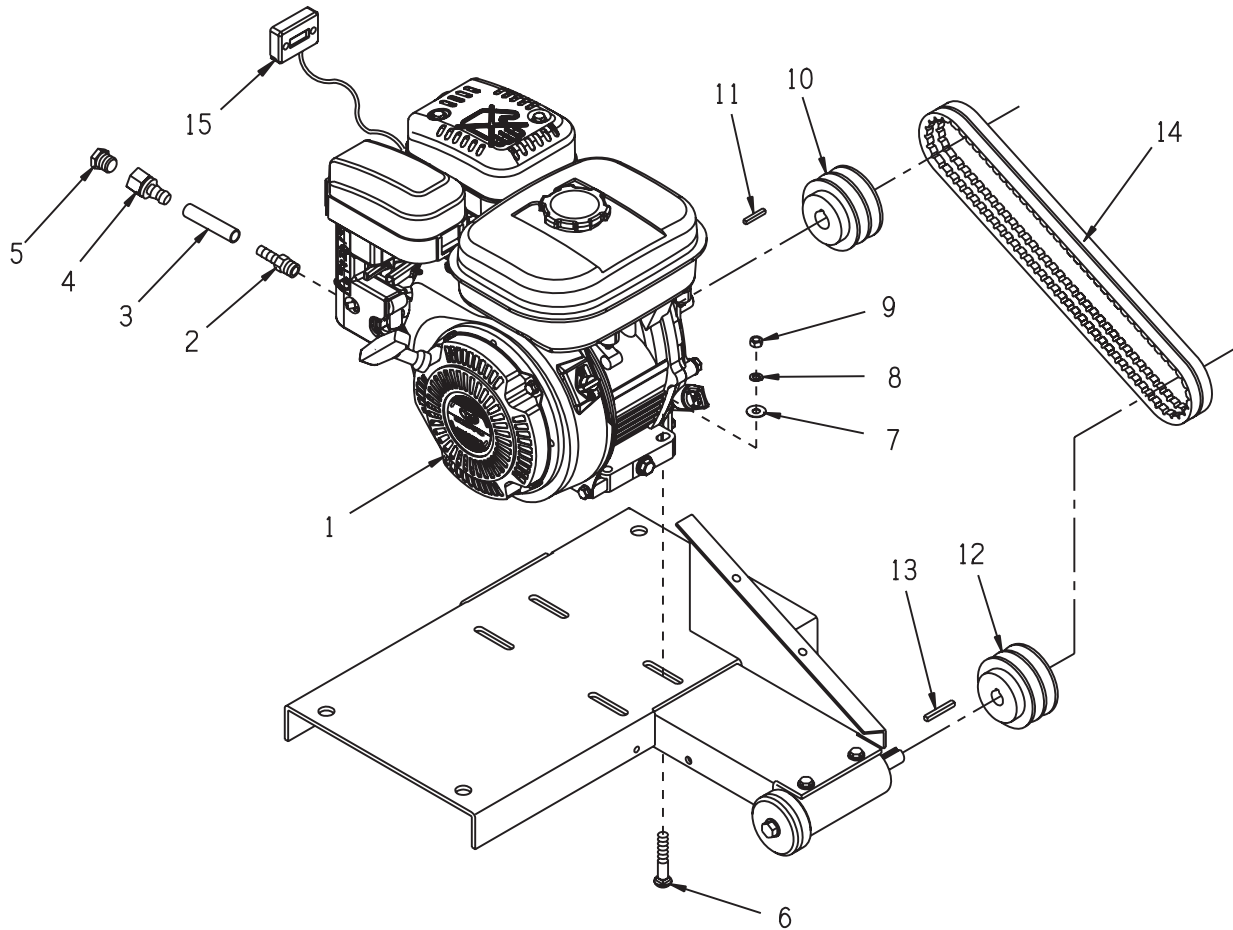

ITEM #	PART #	DESCRIPTION	QTY.
1		ENGINE W/ CYCLONE AIR CLEANER	1
	15060	SUBARU ROBIN EX13D CYC.A.C. (SHOWN)	
	15044	HONDA GX120U1-QXC9 CYC. A.C.	
2	11541	BARB, PUSH-ON 3/8 HOSE X10MM X 1.25	1
3	56116	HOSE, PUSH-ON 3/8"ID X 3"L	1
4	11544	BARB, PUSH-ON 3/8 HOSE X 1/4FPT	1
5	10776	PIPE PLUG 1/4 NPT (BRASS)	1
6	10817	BOLT, CARRIAGE 5/16-18 X 1-1/2 F.T.	4
7	10213	WASHER, FLAT 5/16 SAE	4
8	10801	WASHER, LOCK 5/16	4
9	10054	NUT 5/16-18	4
10	40005	SHEAVE 3"OD X 2 GR.A X 3/4"BORE	1
11	-----	KEY 3/16"SQ. (INCLUDED W/ ENGINE)	1
12	42219	SHEAVE 3"OD X 2 GR.A X 5/8"BORE	1
13	10016	KEY 3/16SQ X 1-1/2	1
14	81007	BELT AX-33	2
15	15138	METER, HOUR, REDINGTON INDUCTIVE (OPTIONAL)	1

## ILLUSTRATION 5: MOTOR GROUPING

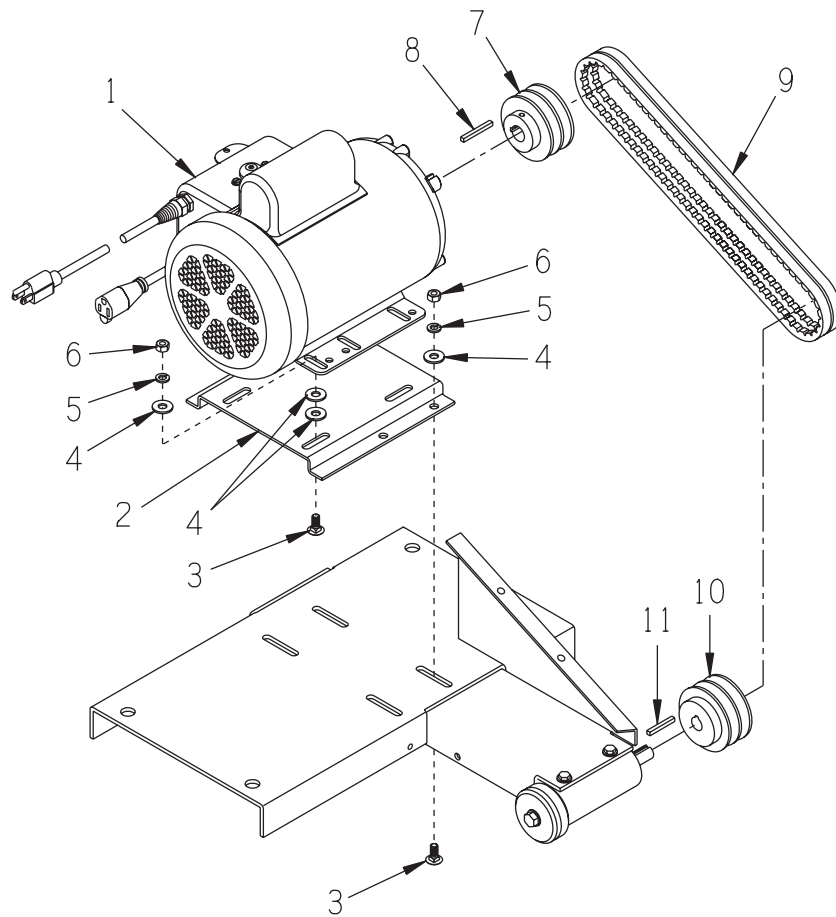

ITEM #	PART #	DESCRIPTION	QTY.
1	16061	MOTOR, BALDOR 1.5HP-1P 60HZ 3450RPM 115/230V SPEC. NO. 35V801R760G1	1
		<i>REPLACEMENT PARTS:</i>	
	16164	CAPACITOR, RUN, BALDOR OC3040F09SP	
	16163	RESET BUTTON, BALDOR TPCRT40CA	
	40051	CAPACITOR, START, BALDOR EC1645A06SP	
	16510	SWITCH, TOGGLE DPST 20A SPAD	
2	42237	MOUNT BRKT., MOTOR	1
3	10819	BOLT, CARRIAGE 5/16-18 X 1 FULL THD	8
4	10213	WASHER, FLAT 5/16 SAE	16
5	10801	WASHER, LOCK 5/16	8
6	10054	NUT 5/16-18	8
7	40005	SHEAVE 3"OD X 2 GR.A X 3/4"BORE	1
8	10060	KEY 3/16 SQ X 1-1/4	1
9	10283	BELT AX-35	2
10	42219	SHEAVE 3"OD X 2 GR.A X 5/8"BORE	1
11	10016	KEY 3/16SQ X 1-1/2	1

**ILLUSTRATION 6: OPTIONAL PROCART**

**PART# 24750C**

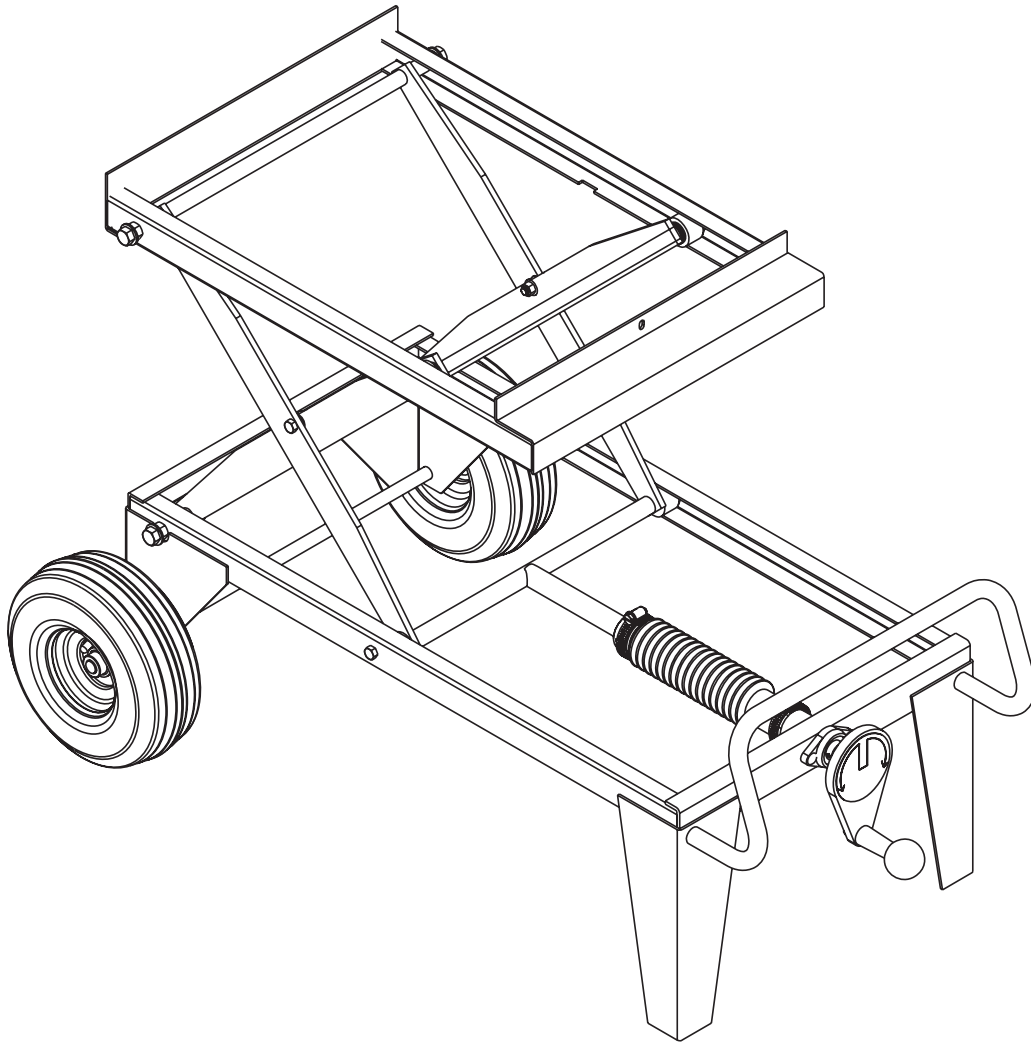

**ADJUSTABLE SCISSOR STYLE CART**

REFER TO THE PROCART PARTS LIST MANUAL  
FOR THE PARTS BREAKDOWN INFORMATION

**ILLUSTRATION 7: OPTIONAL FOLDING STAND**

**PART# 24150C**

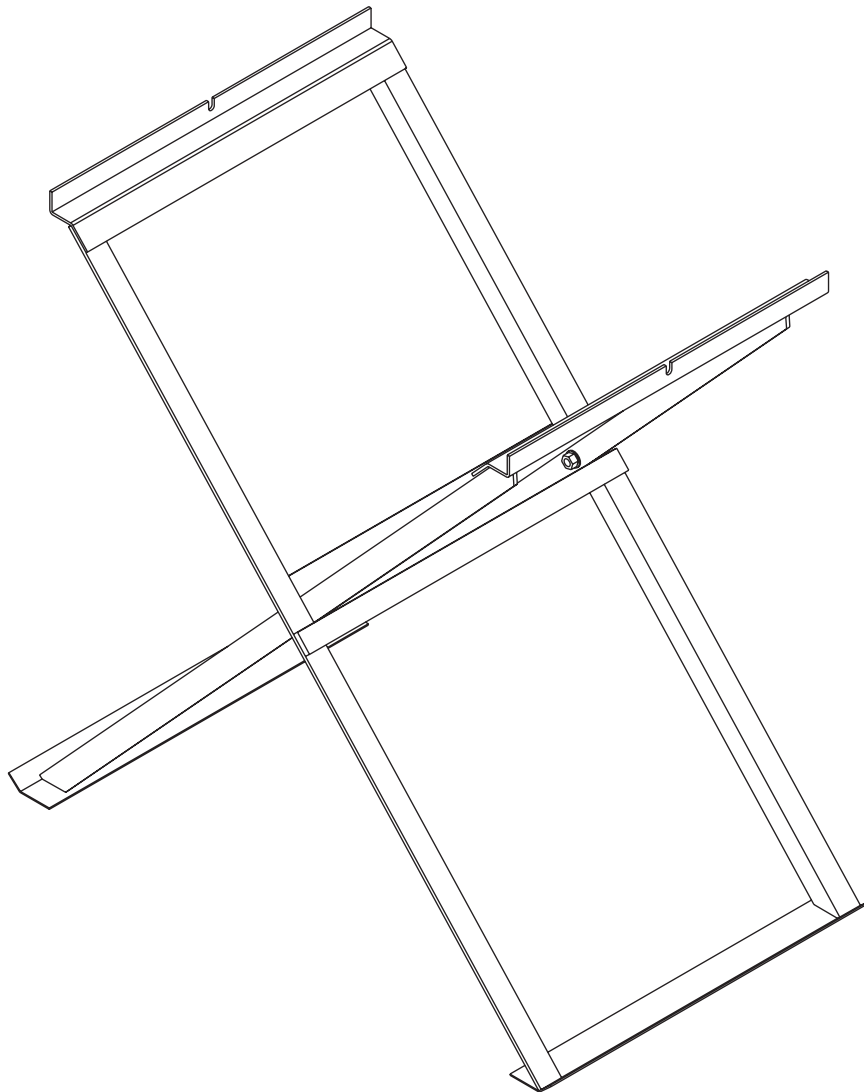

**ILLUSTRATION 8: OPTIONAL WATER PUMP KIT**

**PART# 24625**

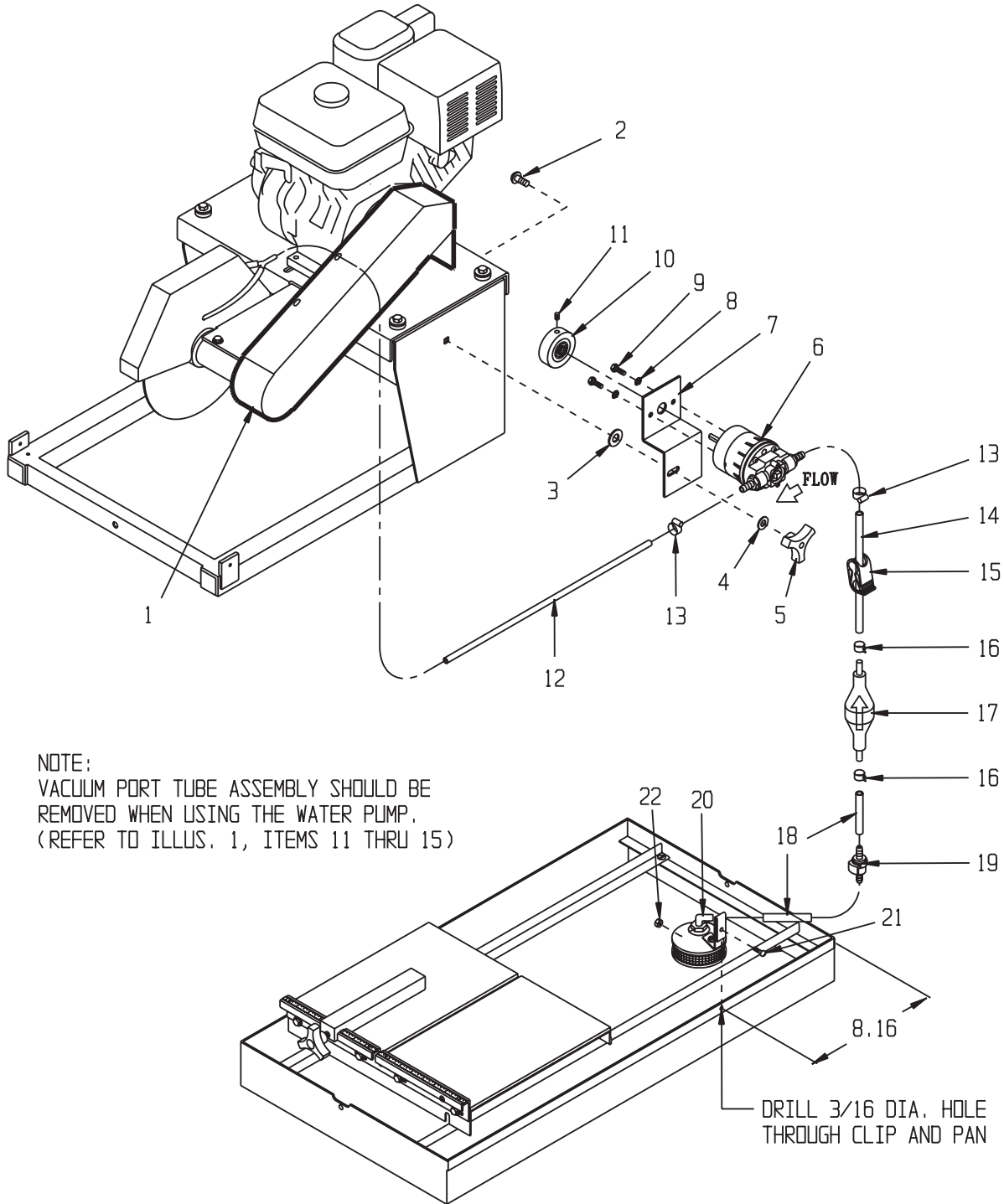

<b>PARTS LISTING - ILLUSTRATION 8: OPTIONAL WATER PUMP KIT</b>			
<b>ITEM #</b>	<b>PART #</b>	<b>DESCRIPTION</b>	<b>QTY.</b>
1	42223	COVER, BELT, WATER PUMP OPTION	1
2	10802	BOLT, CARRIAGE 3/8-16 X 1 FULL THD.	1
3	10312	WASHER, FLAT 1/2 SAE	1
4	10025	WASHER, FLAT 3/8 SAE	1
5	80011	KNOB, 3-PRONG W/ 3/8-16 THD.	1
6	42230	PUMP ASSY., WATER (REFER TO ILLUSTRATION 9 FOR BREAKDOWN)	1
7	42211	BRACKET, WATER PUMP	1
8	10038	WASHER, LOCK 1/4	2
9	10018	SCREW, CAP 1/4-20 X 3/4	2
10	40624	WHEEL, WATER PUMP 2-1/8"	1
11	10161	SCREW, SET 1/4-28 X 5/16	1
12	42143	HOSE 1/4"ID X 18"L	1
13	10714	CLAMP, HOSE, SAE #4, ADJ. TO 5/8"	2
14	42232	HOSE 5/16"ID X 8"L	1
15	42131	CLAMP, TUBE, FLOW CONTROL 3/4"	1
16	10763	CLAMP, HOSE SPRING-TYPE 7/16" RED	2
17	40049	BULB, PRIMER 5/16"	1
18	42233	HOSE 5/16"ID X 3"L	2
19	42234	COUPLING, QUICK-DISCONNECT 3/8" STD	1
20	42235	FILTER ASSY., WATER	1
21	10833	SCREW, MACHINE 10-32 X 3/4	1
22	10832	NUT, KEPS 10-32	1

**ILLUSTRATION 9: WATER PUMP ASSEMBLY**

PART # 42230

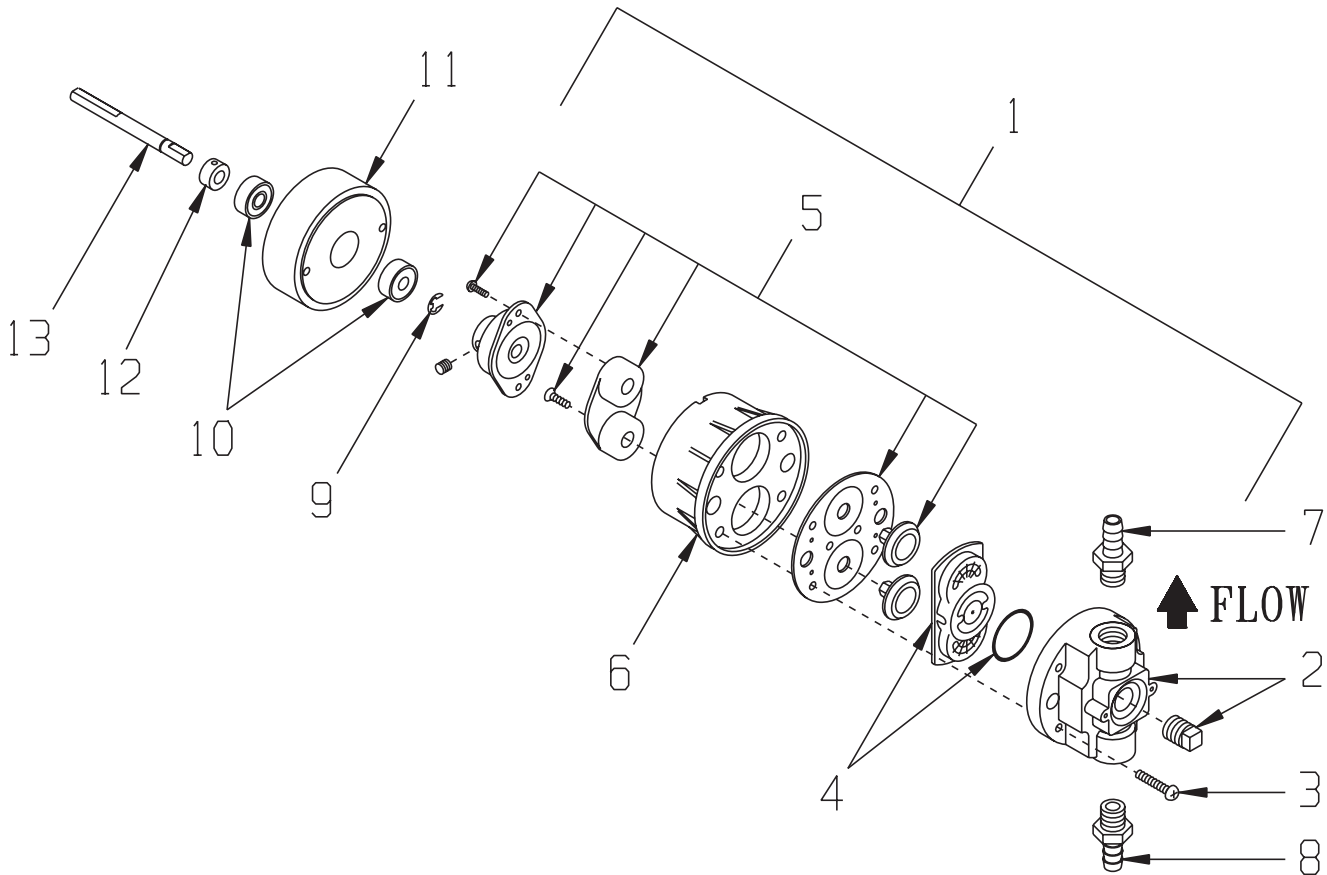

ITEM #	PART #	DESCRIPTION	QTY.
1	56101-S1	PUMP HEAD REPLACEMENT, DUPLEX 21050-653A (INCLUDES ITEMS 2 THRU 6)	1
2	56101-S2	HOUSING BODY 20500-507	1
3	56101-S3	SCREWS 20131-001 (SET OF 6)	1-SET
4	56101-S4	CHECK VALVE KIT 20028-008	1
5	56101-S5	DIAPHRAGM KIT W/ BEARING 21004-401	1
6	56101-S6	HOUSING BEARING COVER 20428-100	1
7	40337	BARB, 1/4 HOSE x 3/8 MPT (PLASTIC)	1
8	40319	BARB, 5/16 HOSE x 3/8 MPT (PLASTIC)	1
9	10137	RETAINING RING, E-CLIP 5/16	1
10	40391	BEARING, RADIAL BALL 5/16 x 7/8 x 11/32	2
11	40393-S1	HUB	1
12	10415	COLLAR, LOCKING 5/16" I.D.	1
13	40393-S2	SHAFT 5/16 x 3-3/4	1

## ILLUSTRATION 10: OPTIONAL DRAIN ASSEMBLY

PART# 42250

INCLUDES ITEMS SHOWN BELOW

USE IN PLACE OF DRAIN PLUG  
(ILLUSTRATION 1 - ITEM 4)

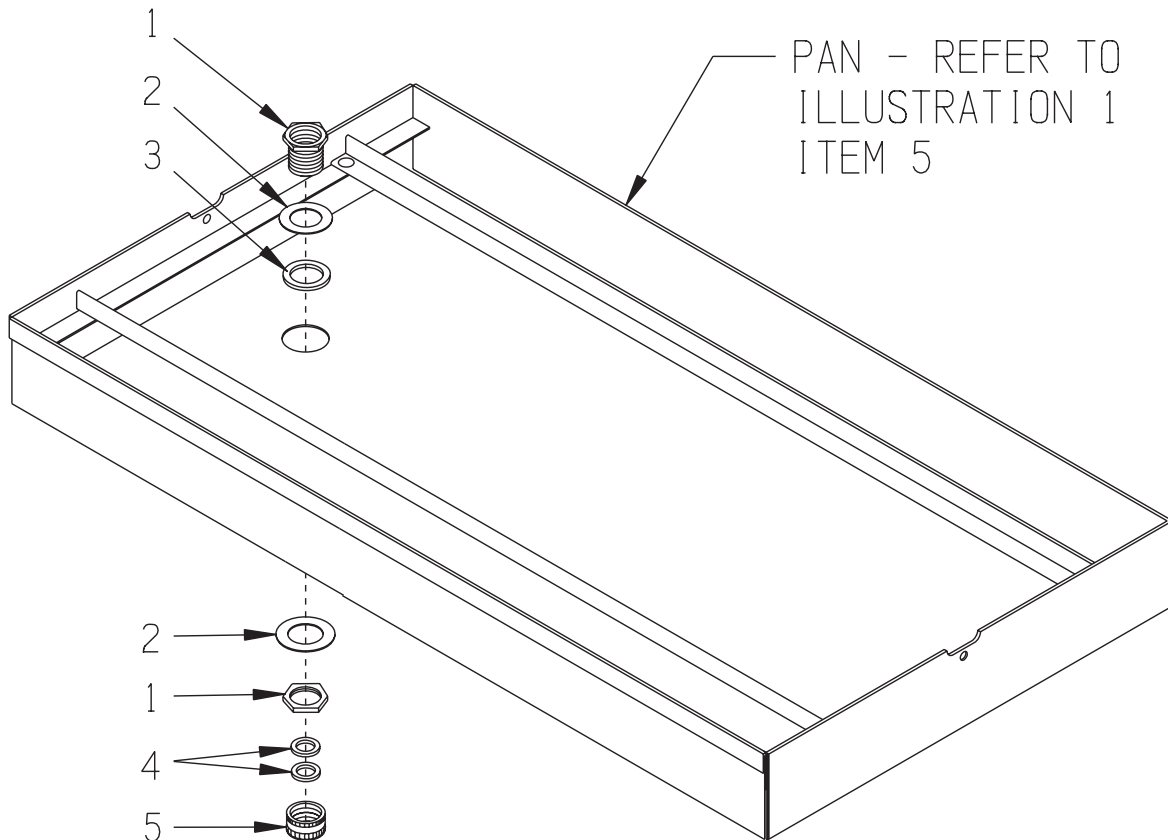

ITEM #	PART #	DESCRIPTION	QTY.
1	42251	FITTING, DRAIN 3/4NH X 1/2FPT (BRASS) (INCLUDES THIN JAM NUT)	1
2	10444	WASHER, ALUM. 1.885ODX1.060IDX .040	2
3	42252	WASHER, RUBBER 1-1/16IDX1-1/2ODX1/8	1
4	10070	WASHER, HOSE 3/4	2
5	42253	CAP, HOSE END (BRASS)	1

**ILLUSTRATION 11: OPTIONAL 115V WATER PUMP KIT**

**PART# 42320**

**ELECTRIC MODEL ONLY**

Connect the white plastic adapter fitting to the garden hose fitting that runs to the blade guard. Submerge the pump in water. Note: The pump may interfere with the rolling table if used in the pan. It can be used from a bucket, barrel or a external pan filled with water. Then connect the male plug to the female connector that is on the motor. The pump will now turn on and off with the motor.



**KIT INCLUDES:**

- 115 VAC SUBMERSIBLE PUMP . . . . . P/N 42130
- BRASS HOSE BARB 1/4HOSE X 1/4FPT . . . . . P/N 40415
- 6FT. PVC TUBING 1/4"ID . . . . . P/N 11532
- ADAPTER FITTING, MALE GHT X 1/4BARB . . . P/N 42321

CD1023

**WIRING DIAGRAM FOR BALDOR MOTOR - 35V801R760G1 1.5HP 1-PHASE 60HZ**

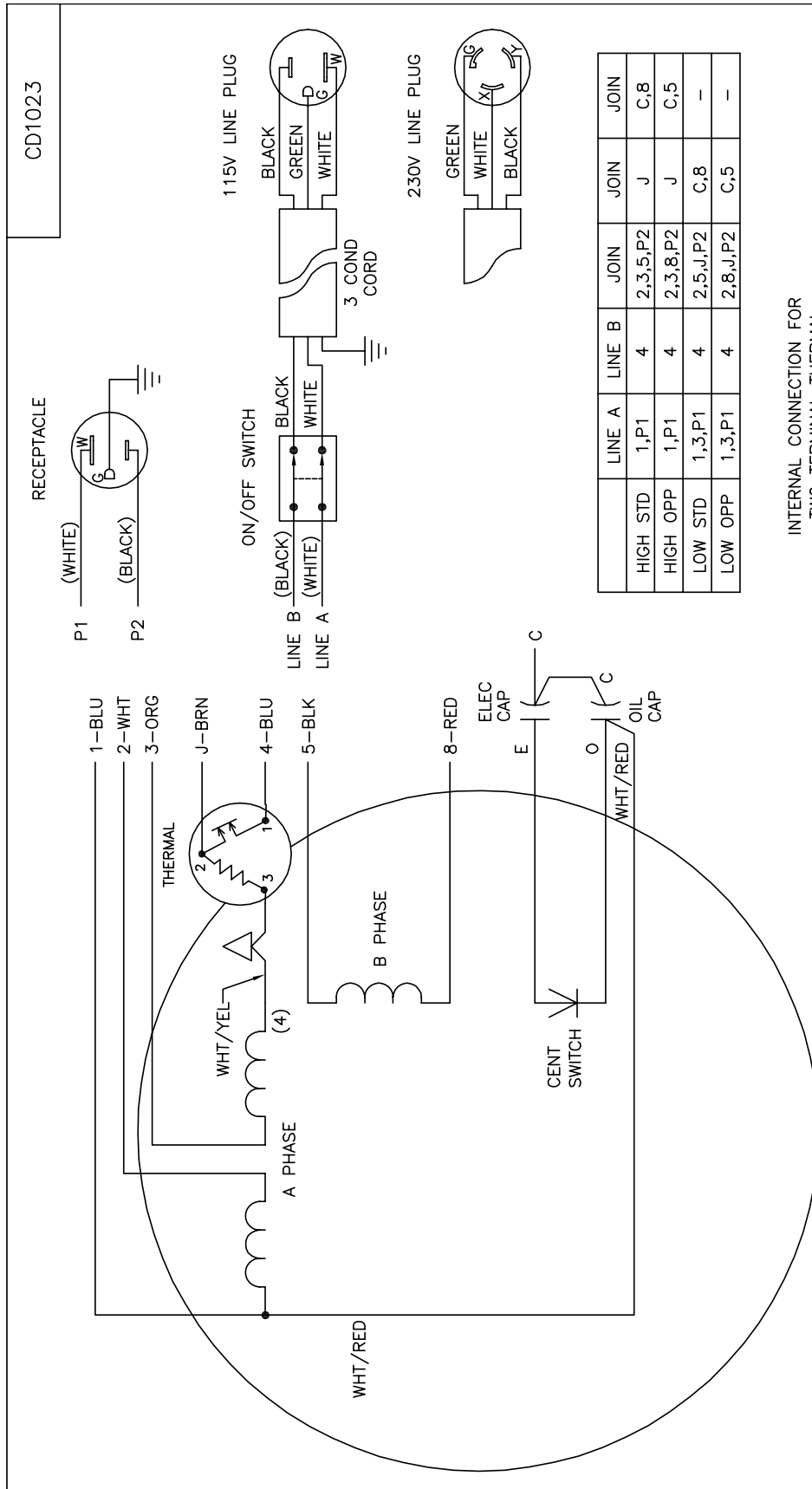

LINE	A	LINE	B	JOIN	JOIN	JOIN
HIGH STD	1,P1	4	2,3,5,P2	J	C,8	C,8
HIGH OPP	1,P1	4	2,3,8,P2	J	C,5	C,5
LOW STD	1,3,P1	4	2,5,J,P2	C,8	-	-
LOW OPP	1,3,P1	4	2,8,J,P2	C,5	-	-

INTERNAL CONNECTION FOR TWO TERMINAL THERMAL

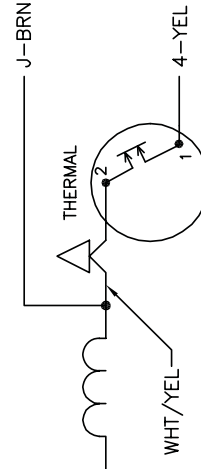

- NOTES:
- STANDARD ROTATION IS CCW FACING END OPPOSITE SHAFT EXTENSION.
  - MULTIPLE CAPACITORS ARE CONNECTED IN PARALLEL UNLESS OTHERWISE SPECIFIED.
  - LEAD COLORS ARE OPTIONAL. LEADS MUST ALWAYS BE NUMBERED AS SHOWN.

REV. DESC: ADD OPTIONAL LEAD COLORS		TDR: 248206	
REV. LTR: B	BY: JLP	REVISED: 10/01/18	08/27/2001
CD1023		FILE: AAA00018033	REF: CD1023
MPL: -			

**BALDOR ELECTRIC Co.**

TYPE LC, DV, REV, THERMAL, 8 LD, LINE SW, CORD, PLUG, 115V RECEPT



THIS PAGE LEFT BLANK INTENSIONLLY

**LIMITED EQUIPMENT WARRANTY OF SALE – TERMS & CONDITIONS**

Equipment Development Company, Inc. herein referred to as EDCO (Seller) warrants that each new unit manufactured by EDCO to be free from defects in material and workmanship in normal use and service for a period of (1) one year (except for the cutter drum assembly on all model concrete/asphalt planes, in which case the warranty period shall be 90 days) from date of shipment to the original retail or equipment rental center owner.

Accessories or equipment furnished and installed on the product by EDCO but manufactured by others, including, but not limited to engines, motors, electrical components, transmissions etc., shall carry the accessory manufacturers own warranty.

EDCO will, at its option, repair or replace, at the EDCO factory or at a point designated by EDCO, any part which shall appear to the satisfaction of EDCO inspection to have been defective in material or workmanship.

EDCO reserves the right to modify, alter and improve any part or parts without incurring any obligation to replace any part or parts previously sold without such modified, altered or improved part or parts.

This warranty is in lieu of and excludes all other warranties, expressed, implied, statutory, or otherwise created under applicable law including, but not limited to the warranty of merchantability and the warranty of fitness for a particular purpose in no event shall seller or the manufacturer of the product be liable for special, incidental, or consequential damages, including loss of profits, whether or not caused by or resulting from the negligence of seller and/or the manufacturer of the product unless specifically provided herein. In addition, this warranty shall not apply to any products or portions thereof of which have been subjected to abuse, misuse, improper installation, maintenance, or operation, electrical failure or abnormal conditions and to products which have been tampered with, altered, modified, repaired, reworked by anyone not approved by seller or used in any manner inconsistent with the provisions of the above or any instructions or specifications provided with or for the product

**FORCE MAJEURE**

Seller's obligation hereunder are subject to, and Seller shall not be held responsible for, any delay or failure to make delivery of all or any part of the Product due to labor difficulties, fires, casualties, accidents, acts of the elements, acts of God, transportation difficulties, delays by a common carrier, inability to obtain Product, materials or components or qualified labor sufficient to timely perform part of or all of the obligations contained in these terms and conditions, governmental regulations or actions, strikes, damage to or destruction in whole or part of manufacturing plant, riots, terrorist attacks or incidents, civil commotions, warlike conditions, flood, tidal waves, typhoon, hurricane, earthquake, lightning, explosion or any other causes, contingencies or circumstances within or without the United States not subject to the Seller's control which prevent or hinder the manufacture or delivery of the Products or make the fulfillment of these terms and conditions impracticable. In the event of the occurrence of any of the foregoing, at the option of Seller, Seller shall be excused from the performance under these Terms and Conditions, or the performance of the Seller shall be correspondingly extended.

This document sets forth the terms and conditions pursuant to which the purchaser ("Purchaser") will purchase and Equipment Development Co. Inc. ("Seller") will sell the products, accessories, attachments (collectively the Products) ordered by the Purchaser. These terms and conditions shall govern and apply to the sale of Seller's Products to Purchaser, regardless of any terms and conditions appearing on any purchase order or other forms submitted by Purchaser to Seller, or the inconsistency of any terms therein and herein.

**1. PRICE**

All prices set forth on any purchase order or other document are F.O.B. Seller's facility or distribution point, as may be determined by Seller (F.O.B. Point). All prices are exclusive of any and all taxes, including, but not limited to, excise, sales, use, property or transportation taxes related to the sale or use of the Products, now or hereafter imposed, together with all penalties and expenses. Purchaser shall be responsible for collecting and/or paying any and all such taxes, whether or not they are stated in any invoice for the Products. Unless otherwise specified herein, all prices are exclusive of inland transportation, freight, insurance and other costs and expenses relating to the shipment of the Products from the F.O.B. point to Purchaser's facility. Any prepayment by Seller of freight insurance and other costs shall be for the account of Purchaser and shall be repaid to Seller.

**2. PAYMENT TERMS**

Payment terms are as follows. 2% 10 days (to approved and qualified accounts). Net 30 days. This is a cash discount for invoices paid within 10 days after the invoice date, regardless of date of receipt of shipment. This is not a trade discount and will not be granted to accounts that do not adhere to stated terms.

\*All past due accounts are subject to a late payment fee of 1.5% per month or a maximum allowed by law if different, along with the expenses incidental to collection including reasonable attorney's fees and costs.

\*Seller reserves the right to hold shipments against past due accounts.

\*Seller reserves the right to alter payment terms.

**3. FREIGHT TERMS**

All shipments will be made F.O.B. shipping point as designated in these Terms and Conditions, and title shall pass at the F.O.B. point. Delivery to the initial common carrier shall constitute delivery to the Purchaser. Any claims for loss or damage during shipment are to be filed with carrier by the Purchaser. Seller will not assume responsibility for the performance of the carrier.

Back orders will be shipped in the most practical fashion with charges consistent with our freight policy established with the original order. UPS, FED EX, MAIL or shipments by other couriers are subject to the same terms and conditions as outlined in paragraph #3 "Freight Terms".

**4. DELIVERY, DAMAGES, SHORTAGES**

Seller shall use reasonable efforts to attempt to cause the Products to be delivered as provided for in these Terms & Conditions. Delivery to the initial common carrier shall constitute the delivery to the Purchaser. Seller's responsibility, in so far as transportation risks are concerned ceases upon the delivery of the Products in good condition to such carrier at the F.O.B. point and all the Products shall be shipped at the Purchaser's risk. Seller shall not be responsible or liable for any loss of income and/or profits, or incidental, special, consequential damages resulting from Seller's delayed performance in shipment and delivery.

**5. RETURN OF DEFECTIVE PRODUCTS**

Defective or failed material shall be held at the Purchaser's premises until authorization has been granted by Seller to return or dispose of Products. Products that are to be returned for final inspection must be returned Freight Prepaid in the most economical way. Credit will be issued for material found to be defective upon Seller's inspection based on prices at time of purchase.

**6. PRODUCTS ORDERED IN ERROR**

Products may be returned, provided that claim is made and Seller is notified within 7 days of receipt of Products, and the Products are in original buyer's possession not more than 30 days prior to return, subject to Seller's approval. If Products are accepted for return, they must be Freight Prepaid and buyer will be charged a minimum of 15% rehandling charge, plus a charge back for outbound freight charges if the original order was shipped prepaid. Returns are not accepted for any Products that are specifically manufactured to meet the buyer's requirement of either specifications or quantity.

**AGREEMENTS**

These Terms and Conditions constitute the entire agreement between Seller and Purchaser as it relates to terms and conditions of sale, and supersedes any and all prior oral or written agreements, correspondence, quotations or understandings heretofore in force between the parties relating to the subject matter hereof. There are no agreements between Seller and Purchaser with respect to the Product herein except those specifically set forth in and made part of these terms and conditions. Any additional terms, conditions and/or prices are rejected by Seller.

These terms and conditions may be modified, cancelled or rescinded only by a written agreement of both parties executed by their duly authorized agents.

**USE ONLY GENUINE EDCO PARTS & ACCESSORIES**  
**For your own safety, the safety of others and the life of your machine.**